

**Attachment 3 Drawing**  
**Solicitation No. 19CE2022Q0014**

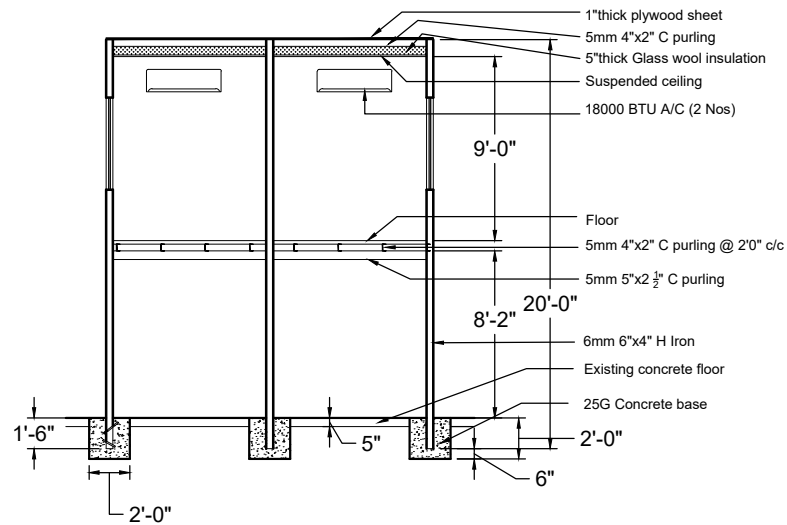

**SECTION ON X-X**

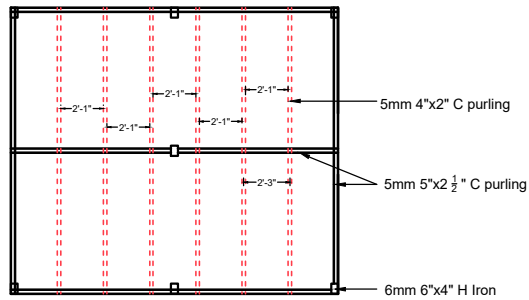

**FLOOR ARRANGEMENT**

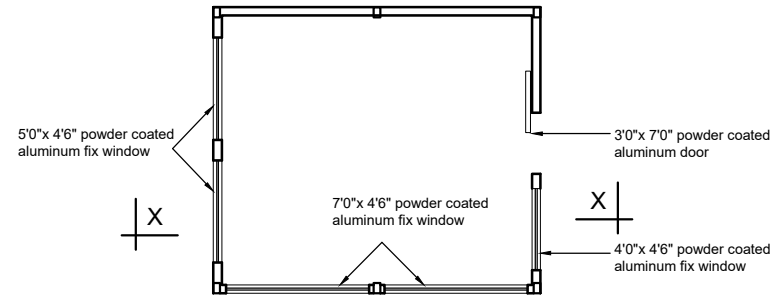

**UPPER FLOOR**

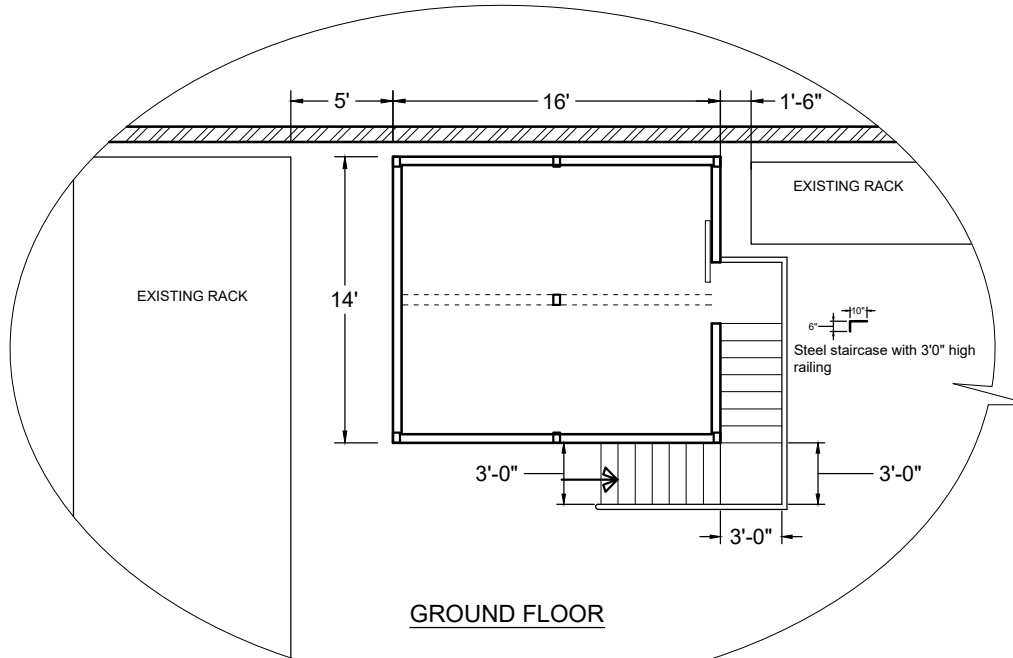

**GROUND FLOOR**

SCALE: 8 FEET TO AN INCH  
 DRAWN BY : SULOCHANA  
 DATE : 07/28/2022

PROJECT  
**NEW MEZZANINE FLOOR**  
**FOR WATHHALA WAREHOUSE**

**US EMBASSY**  
**COLOMBO SRI LANKA**

